













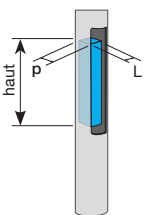
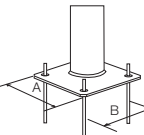

Mâts supports de feux de signalisation / Traffic light columns

LUXEM OC - SIGNA			
	H (m)	2,6 m	3,6 m
	DE (mm)	156	
	DA (mm)	89	
	LP (mm)	97	
	HP (mm)	500	
	HSP (mm)	400	
	L (mm)	90	
	p (mm)	80	
	haut (mm)	460	
	A (mm)	270	
	B (mm)	200	
	Ø x lg (mm)	JT-M14 x 300	
	Mf (N.m)	6129	5564
	Et (N)	2530	1880
	c ² x h (m)	0,5 ² x 0,7	0,4 ² x 0,7
	m (kg)	28	35
	le (m)	0,76	0,86
	d (m)	0,5	

Surface maximale admissible - Maximum allowable surface area

Type de mât Type of column	LUXEM OC SIGNA
Données techniques Data sheet	

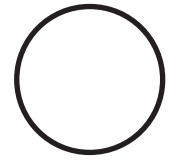

Enjoliveurs de tête en option
Optional head covers

- Boule aluminium
Aluminium ball
- Bouchon noir pénétrant
Penetrating black plug
- Bouchon bombé aluminium
Domed aluminium cap

